



asp

support and protect

## UNIVERSAL STAIR 68 SERIES



User Guide

# FOREWORD

---

In 2003/2004 67 people died and nearly 4000 suffered a serious injury as a result of a fall from height in the workplace.

Falls from height are the most common cause of fatal injury. The Work at Height Regulations 2005 came into effect on 6 April 2005. The Regulations will apply to all work at height where there is a risk of a fall liable to cause personal injury.

The Regulations place duties on employers, the self-employed, and any person that controls the work of others. The Regulations do not apply to the provision of paid instruction or leadership in caving or climbing by way of sport, recreation, team building or similar activities.

As part of the Regulations, duty holders must ensure:

- all work at height is properly planned and organised;
- those involved in work at height are competent;
- the risks from work at height are assessed and appropriate work equipment is selected and used;
- the risks from fragile surfaces are properly controlled; and
- equipment for work at height is properly inspected and maintained.

The Regulations include schedules giving requirements for existing places of work and means of access for work at height.

The regulations provide a simple hierarchy for managing and selecting equipment for work at height, you must:

- avoid work at height where you can;
- use work equipment or other measures to prevent falls where you cannot avoid working at height; and
- where you cannot eliminate the risk of a fall, use work equipment or other measures to minimise the distance and consequences of a fall should one occur.

The ideal means of access for any work at height is a purpose-made stair tower, but previously these have been time-consuming and thus costly to build in traditional scaffolding. System scaffold stairs are available, but they are made in fixed lift heights which make them unsuitable for traditional scaffolds. They require the use of the system to build the complete tower and relatively few scaffold companies have system kit in their inventories.

These difficulties are now overcome by the ASP Universal Stair Range which can be used for vertical access within scaffolds or falsework structures. A range of head and base units are available enabling connection of the stair units to scaffold tubes, system scaffold transoms, timber floors and slab edges.

Universal Stair is a simple self-contained product which is easy to store packed flat and can be collected or delivered on small vehicles including vans for the smaller models. Product selection is easy, depending only on the range of lift heights required, and users have the assurance that all models, in all possible positions, are fully-compliant with regulations.

Non-scaffolding users will find Universal Stair easy to use, since there are no special skills involved in producing a first-class result

ASP Universal stairs are classified Class B compliant to BS EN12811.

# INDEX

---

This guide is suitable for users of the Universal Stair 68 Series..

1.0	Introduction	page	<b>02</b>
2.0	Component recognition	page	<b>03</b>
3.0	Assembly	page	<b>04</b>
3.1	Basic Assembly	page	<b>04</b>
3.2	Alternative head connections	page	<b>07</b>
4.0	Technical data	page	<b>08</b>
4.1	Model information	page	<b>08</b>
4.2	Geometry	page	<b>09</b>
4.3	Structural performance data	page	<b>11</b>
4.4	Typical layouts	page	<b>12</b>
5.0	Specific risks and hazards to health	page	<b>13</b>
6.0	Inspection and maintenance	page	<b>13</b>
7.0	Delivery and storage	page	<b>14</b>

## INTRODUCTION

---

### 1.0 Introduction

Universal Stair is a range of self-contained, pre-assembled aluminium stair units, flat packed, which automatically adjust to a wide range of lift heights, making them ideal for use in tube and fitting scaffolds. Vitally important, Universal Stair is fully-compliant with BS EN12811 for all possible configurations.

# COMPONENT RECOGNITION

## 2.0 Component Recognition

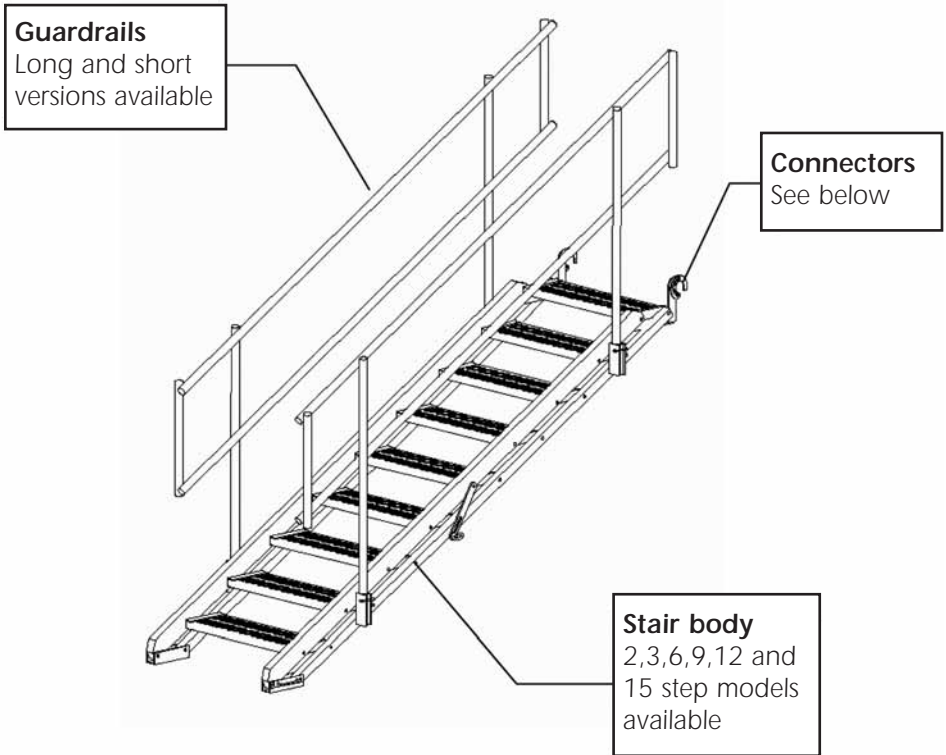

### Connectors

Supplied with scaffold hooks as standard.

Options available for concrete slabs, timber joists and system scaffolds.

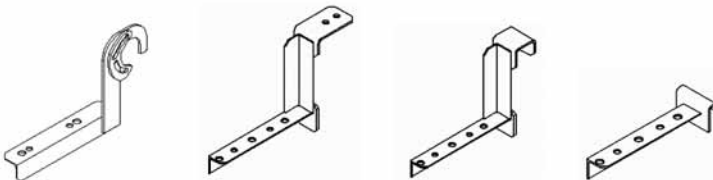

# ASSEMBLY

## 3.0 Assembly

### 3.1 Basic Assembly

**STAGE 1 :** Connect stair to tube or surface.

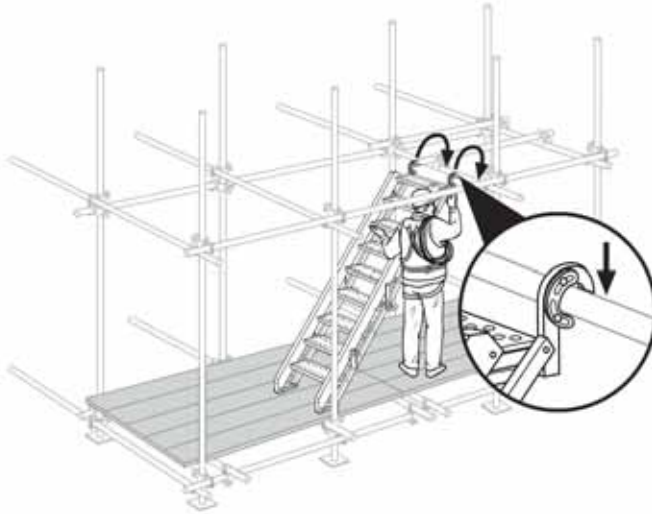

**STAGE 2 :** Insert guard rails into side mounted pockets.

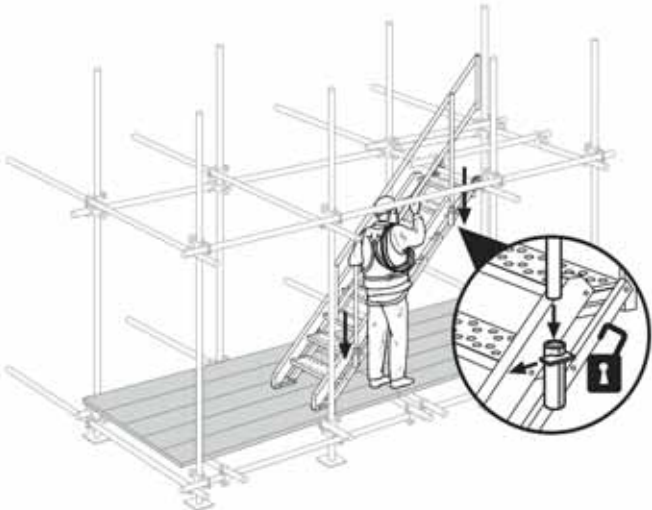

**STAGE 3 :** Push guard rails to articulate stairs and to level treads.



**STAGE 4 :** Using a suitable lever or podger, lock the stair eye bolts.

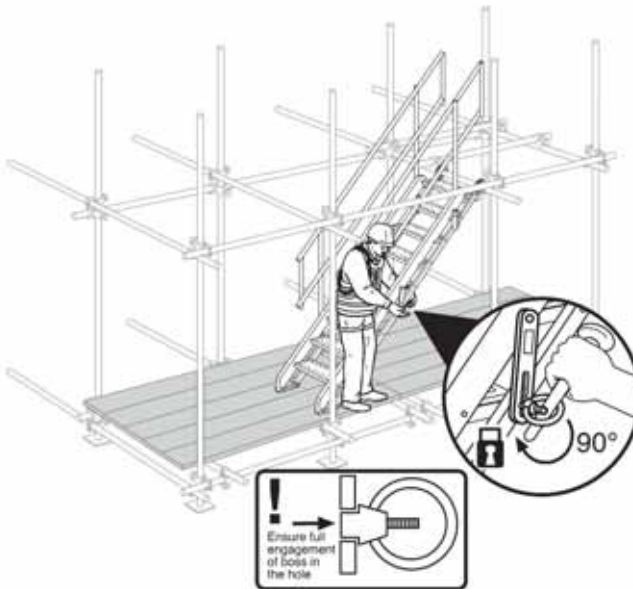

**STAGE 5 :** Lock the guard rails using integral wedge fastening.

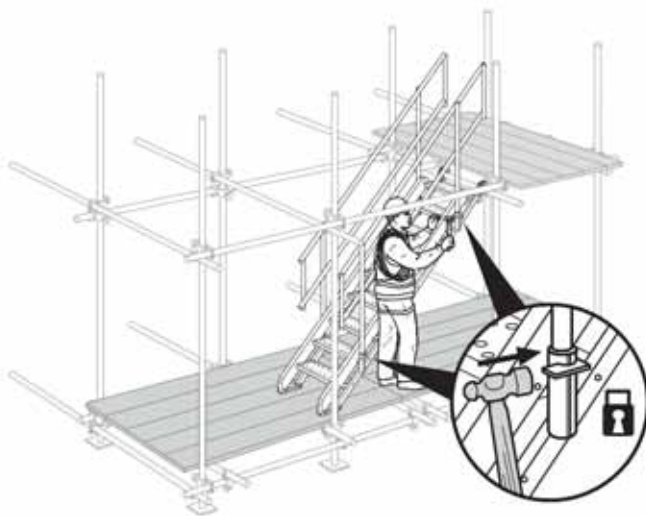

**SUITABLE PPE SHOULD BE WORN DURING ALL OPERATIONS!**

# ALTERNATE HEAD CONNECTORS

## 3.2 Alternative head connections

### 3.2.1 For connection to Scaffold tubes of diameter 48.3mm.

Use bracket Part 22130001.

Note this is the default bracket that each stair is supplied with

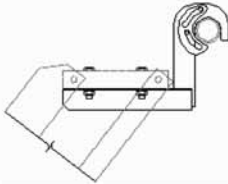

### 3.2.2 Connection to horizontal surfaces.

Use Part 22130002 fixed with screws or nails into load bearing surface.

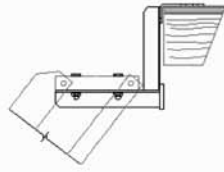
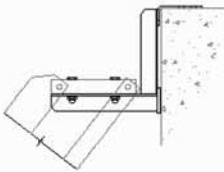

### 3.2.3 Connection to 48.3mm tubes and timber joists less than 50mm width.

Use Part 22130004.

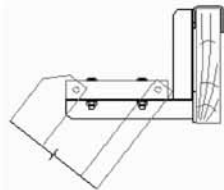
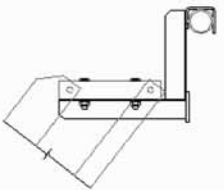

### 3.2.4 Connection to system scaffold transoms.

For Kwikstage batten transom use Part 22130003

For Cuplok Omega Transom use Part 22130005

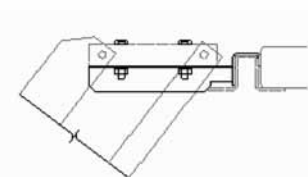
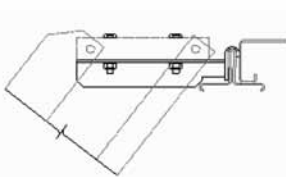

# TECHNICAL DATA

## 4.0 Technical data

### 4.1 Model information

#### 4.1.1 Stair Assemblies

Part No	Description	Comment	Weight
22110001	Model 1	No guardrails, Scaffold hooks inclusive	11.9kg
22110002	Model 2		19.7kg
22110003	Model 3		29.8kg
22110004	Model 4		39.2kg
22110005	Model 5		47.0kg
22100002	Model 2	All guardrails and scaffold hooks inclusive	29.7kg
22100003	Model 3		42.0kg
22100004	Model 4		59.2kg
22100005	Model 5		81.4kg

#### 4.1.2 Guardrail Units

Part No	Description	Weight
22120001	Guardrail, Short	5.0
22120002	Guardrail, Long	6.1

#### 4.1.3 Hanger Brackets

Part No	Description	Weight
22130001	Universal Stair scaffold hooks (pair)	2.0kg
22130002	Universal Stair slab hanger (pair)	2.9kg
22130003	Universal Stair KS hanger (pair)	3.9kg
22130004	Universal Stair LR hanger (pair)	2.9kg
22130005	Universal Stair OM hanger (pair)	4.9kg

See section 3.2 above for details of bracket use.

#### 4.1.4 Stair Guardrail Requirements

Model Number	Number of guardrails	
	Short	Long
1	-	-
2	2	-
3	-	2
4	4	-
5	2	2

# GEOMETRY

## 4.2 Model geometry

### 4.2.1 Model Application Range

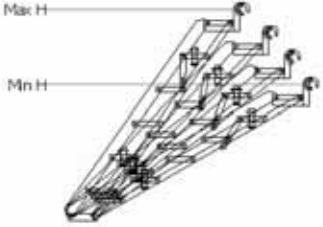
	Model Number	Application Range	
		Min H(m)	Max H(m)
	1	0.56	0.83
	2	0.95	1.47
	3	1.37	2.17
	4	1.80	2.87
	5	2.23	3.57

Note the above table relates to application range when using hanger bracket 22130001 only.

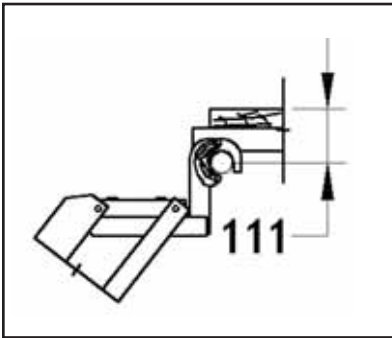

Additional height H using bracket 22130001

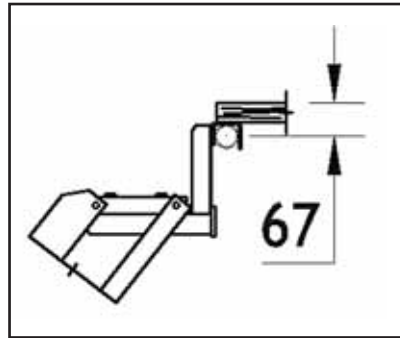

Additional height H using bracket 22130004

### 4.2.2 Tread details

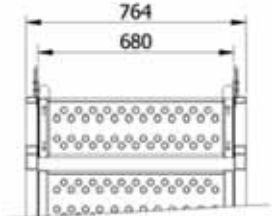
Model	Number of Treads	Tread Width (m)	
1	3	0.68	
2	6	0.68	
3	9	0.68	
4	12	0.68	
5	15	0.68	

### 4.2.3 Space requirement

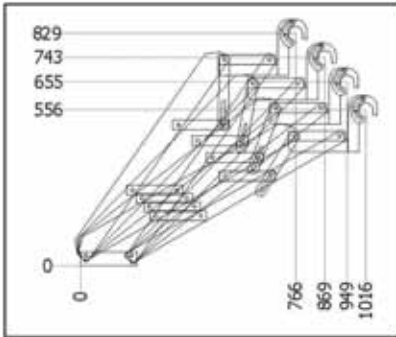

Model 1

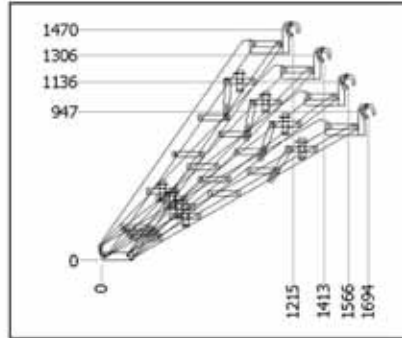

Model 2

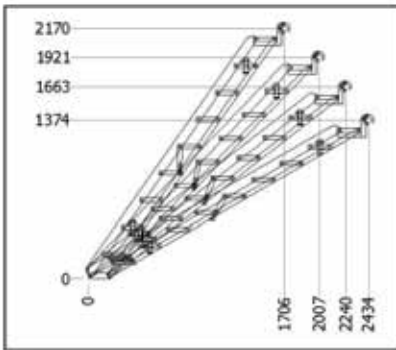

Model 3

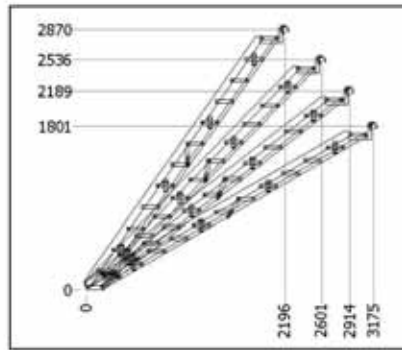

Model 4

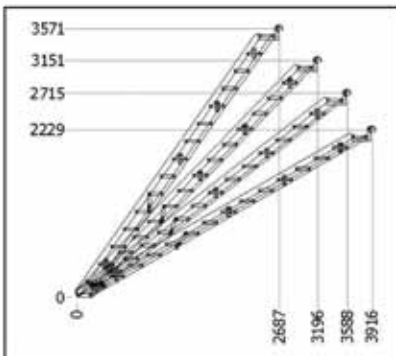

Model 5

# STRUCTURAL PERFORMANCE DATA

## 4.3 Structural performance data. Safe working loads.

Model Number	Uniformly distributed load kN/m <sup>2</sup>	Point Load kN
1	>2.5	1.5
2	>2.5	1.5
3	>2.5	1.5
4	>2.5	1.5
5	2.5	1.5

Note: Uniformly distributed load case assumes every tread loaded simultaneously.  
Point load case is maximum per tread.

# TYPICAL LAYOUTS

## 4.4 Typical layouts

### 4.4.1 Typical Layout 1, Parallel to scaffold.

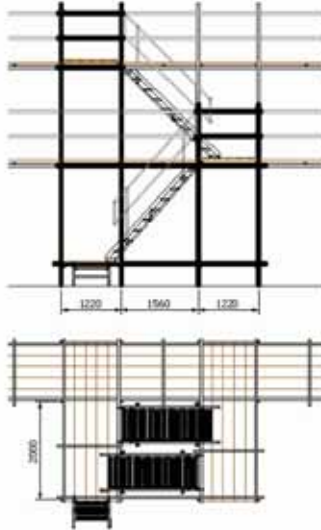

### 4.4.2 Typical Layout 2, Perpendicular to scaffold.



# SPECIFIC RISKS & HAZARDS

## 5.0 Specific risks and hazards to health

### 5.1 During Installation

Appropriate PPE should be worn at all times whilst installing ASP Universal Stairs. A minimum recommendation is leather gloves, steel toe cap boots and a hard hat. Manual handling, lifting and placement of the Universal Stairs requires a minimum of 2 men above Model 2.

Do not place fingers under the treads at the tread/stringer intersection whilst adjusting the stair. This gap opens and closes during adjustment prior to fixing of the locking stay.

Ensure that all guardrails and toe boards are fitted and secured at each landing position.

### 5.2 Following Installation

Keep at least one hand on a guard rail at all times whilst traversing the stairway. Do not run entering, traversing or leaving the stairway as this will greatly increase your chances of tripping.

Ensure that the stair treads are kept free from debris and materials. Materials are not to be stored on the stairs at any time.

Ensure that the stair treads are kept free from grease or oil spillages as this will increase the chances of slipping.

Ensure that the side mounted locking stays are firmly engaged at all times and are not tampered with.

Ensure that the hanging brackets are securely positioned and engaged. Some corrosive environments and extreme temperatures may affect the performance and durability of the alloy stairway. Contact ASP Technical helpdesk for advice if these are suspected.

## 6.0 Inspection and maintenance

### 6.1 Inspection

Inspect weekly and prior to each installation.

#### Checklist:

Check all bolts and nuts are in position and tight. It will be necessary to view the stair from underneath to do this.

Check for looseness of bolts.

Check all treads are free from damage.

Check all stringers are free from damage.

Check upper connection hooks and bolted fixings are secure and free from damage.

Check all guard rail connection sockets for signs of damage.

Check all guard rail connection spigot welds for damage.

### 6.2 Maintenance

ASP Universal stairs are a fully bolted construction and therefore any routine maintenance is straight forward using the minimum of tools.

Tools required 17mm spanner, 8mm allen key.

# DELIVERY & STORAGE

## 7.0 Delivery and storage

### 7.1 Minimum collapsed height

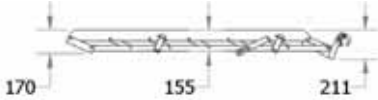

### 7.2 Pack details for storage and transportation

Model No	Pack Quantities	Overall pack sizes	Pack Weight (kg)
1	8	<p>A diagram of a pack of 8 collapsed stair sections. The overall width is 1203 and the overall height is 1360.</p>	96
2	8	<p>A diagram of a pack of 8 collapsed stair sections. The overall width is 2058 and the overall height is 1360.</p>	158
3	8	<p>A diagram of a pack of 8 collapsed stair sections. The overall width is 2913 and the overall height is 1360.</p>	239
4	8	<p>A diagram of a pack of 8 collapsed stair sections. The overall width is 3768 and the overall height is 1360.</p>	314
5	8	<p>A diagram of a pack of 8 collapsed stair sections. The overall width is 4551 and the overall height is 1360.</p>	376

The weights above do not include guardrails.



## UNIVERSAL STAIR 68 SERIES

ASP Registered Design Products are available from:

Advanced Scaffold Products Ltd

Head Office: Unit 2 Bydand Lane Industrial Estate, Little Paxton, St. Neots, Cambs PE19 6EG

Telephone: 0870 609 3370 Fax: 0870 850 3307

Email: [info@asp.gb.com](mailto:info@asp.gb.com)

[www.asp.gb.com](http://www.asp.gb.com)

and nationwide from Hire and Sale stockists